



PLQE

一款安装便捷的行星减速机 发热量低 可承受较高的力

我们的 **PLQE** 结构简单且性能强大。它可以直接和您的系统连接，不需要中间法兰。输出装置上的大型深沟球轴承可以承受较高的轴向力和径向力。它凭借着良好的传动效率，即使在严苛的生产周期内也能始终可靠地运行。

The easy to install planetary gearbox absorbs high forces with low heat generation

Our **PLQE** is uncomplicated and powerful. It can be connected directly to your installation without the need for an intermediate flange. The larger deep groove ball bearings on the output allow higher axial and radial forces to be absorbed. Thanks to its favorable efficiency, this means that it always operates reliably even when production cycles are demanding.

周期性扭矩
Cyclic torque **5 - 260 Nm**

径向力
Radial force **520 - 4000 N**

轴向力
Axial force **620 - 3800 N**

回程间隙
Torsional backlash **7 - 22 arcmin**

防护等级
Protection class **IP54**

结构尺寸
Frame sizes

- 40
- 60
- 80
- 120

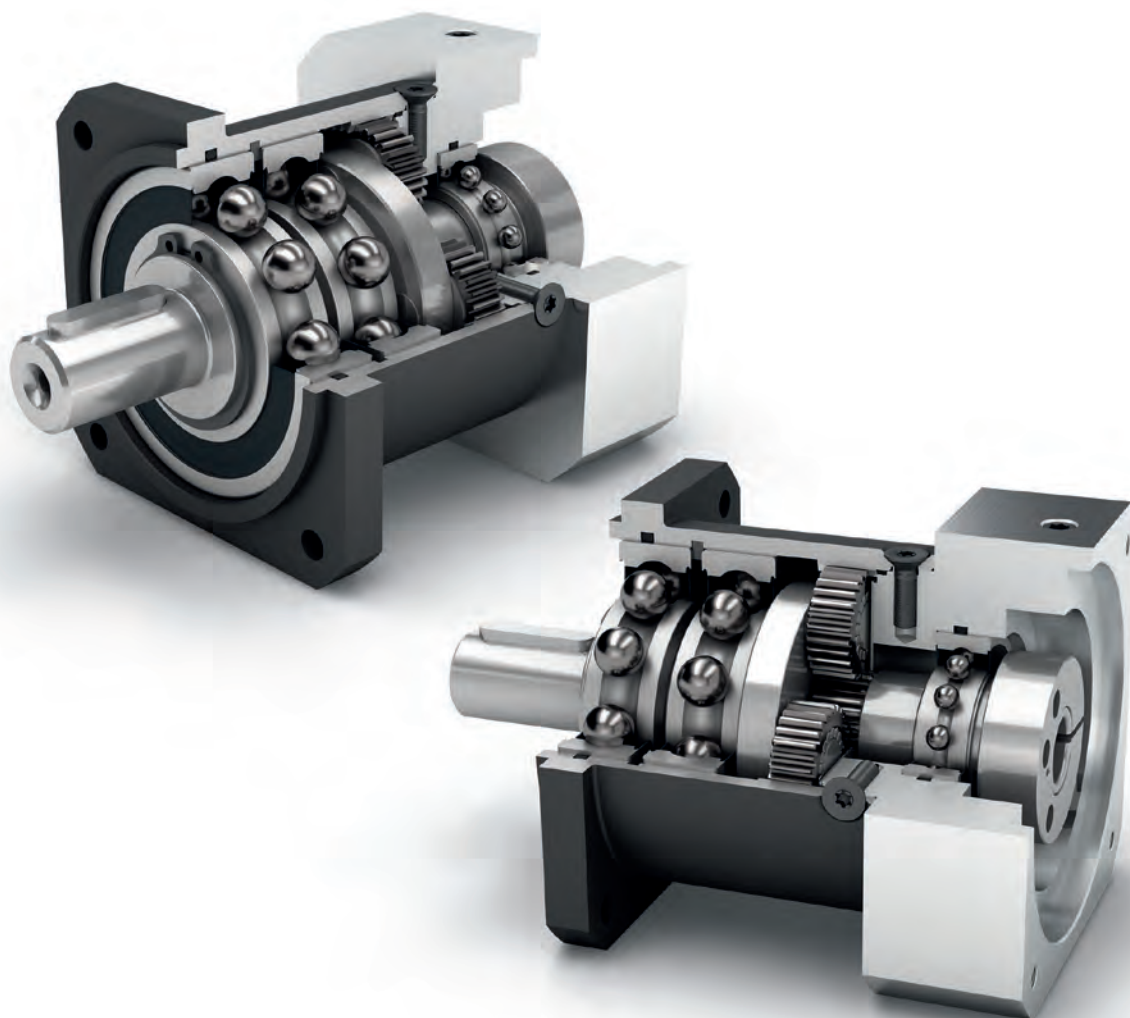

经济型
Economy Line



同轴减速机
Coaxial gearbox



直齿
Spur gear



增强深沟球轴承
Reinforced deep groove ball bearings



行星齿轮架
Planet carrier in disc design



旋转方向 同方向
Equidirectional rotation



正方形输出法兰
Square type output flange



多样的传动比 (i=3 至 i=512)
High ratio variety i=3 up to i=512



可选：喷漆表面
——RAL 9005 黑色
Option: Painted surface
- RAL 9005 Jet black

技术特点的详细解释，请从第201页读起。
Detailed explanations of the technical features starting on page 201.

Code	减速机参数	Gearbox characteristics			PLQE040	PLQE060	PLQE080	PLQE120	p ⁽¹⁾
	使用寿命 ⁽²⁾	Service life ⁽²⁾	L _h	h	20.000				
	有效系数 ⁽³⁾	Efficiency ⁽³⁾	η	%	98				1
97					2				
92					3				
	最低工作温度	Min. operating temperature	T _{min}	°C	-25				
	最高工作温度	Max. operating temperature	T _{max}		90				
	防护等级	Protection class			IP54				
S	标准润滑	Standard lubrication			润滑脂 (终生润滑) / Grease (lifetime lubrication)				
F	食品级润滑	Food grade lubrication			润滑脂 (终生润滑) / Grease (lifetime lubrication)				
	安装位置	Installation position			任意 / Any				
S	标准回程间隙	Standard backlash	φ	arcmin	< 15	< 10	< 7	< 7	1
					< 19	< 12	< 9	< 9	2
					< 22	< 15	< 11	< 11	3
	抗扭刚度 ⁽³⁾	Torsional stiffness ⁽³⁾	C _{2t}	Nm / arcmin	1,2 - 2,2	2,8 - 3,9	8,5 - 12,6	14,0 - 18,5	1
					1,4 - 2,5	3,3 - 4,1	9,4 - 13,3	15,6 - 19,0	2
					1,5 - 2,6	3,3 - 4,1	9,4 - 13,4	15,6 - 19,0	3
	减速机重量 ⁽³⁾	Gearbox weight ⁽³⁾	m	kg	0,4	1,1	2,6 - 3,0	6,4 - 6,7	1
					0,5	1,3	3,4 - 3,5	8,1 - 8,5	2
					0,6	1,5	3,9 - 4,0	9,9 - 10,3	3
S	标准的箱体表面	Standard surface			箱体: 钢 - 热处理后氧化 (黑色) Housing: Steel - heat-treated and post-oxidized (black)				
B	喷漆表面 ⁽⁴⁾	Painted surface ⁽⁴⁾			RAL 9005 黑色 RAL 9005 Jet black				
	运行噪音 ⁽³⁾	Running noise ⁽³⁾	L _{pA}	dB(A)	58	58	60	65	

输出轴载荷	Output shaft loads			PLQE040	PLQE060	PLQE080	PLQE120	p ⁽¹⁾
最大径向力	Maximum radial force	F _{r max}	N	520	1500	2500	4000	
最大轴向力	Maximum axial force	F _{a max}		620	1950	3800	3800	
最大倾斜力矩	Maximum tilting moment	M _{K max}	Nm	14	62	124	314	

输入特性	Input characteristics			PLQE040	PLQE060	PLQE080	PLQE120	p ⁽¹⁾
输入端锁紧系统直径 (代码)	Clamping system diameter input (Code)	D26	mm	8 (A)	11 (C)	19 (E) ⁽⁵⁾	24 (F) ⁽⁵⁾	
				9 (B) ⁽⁵⁾	14 (D) ⁽⁵⁾	24 (F)	35 (G)	
				11 (C)	19 (E)	-	-	
转动惯量 ⁽³⁾⁽⁵⁾	Mass moment of inertia input ⁽³⁾⁽⁵⁾	J ₁	kgcm ²	0,022 - 0,035	0,086 - 0,162	0,371 - 0,783	1,381 - 2,393	1
				0,022 - 0,032	0,086 - 0,143	0,366 - 0,625	1,414 - 2,292	2
				0,022 - 0,031	0,086 - 0,096	0,365 - 0,590	1,413 - 2,196	3
平均空载扭矩 ⁽³⁾⁽⁵⁾	Average idle torque ⁽³⁾⁽⁵⁾	T ₀	Nm	0,05 - 0,15	0,10 - 0,20	0,25 - 0,55	0,50 - 1,05	1
				0,05 - 0,15	0,10 - 0,15	0,20 - 0,30	0,45 - 0,80	2
				0,05 - 0,10	0,10	0,15 - 0,20	0,45 - 0,75	3
基于减速机输入法兰的最大弯矩	Max. bending moment based on the gearbox input flange	M _{b1}		4,5	12	16	40	

(1) 减速机级数

(2) 利用 NCP 针对应用进行专门设计 - www.neugart.com

(3) 传动比相关的数值可在 Tec Data Finder 中检索 - www.neugart.com

(4) 更多信息见第 183

(5) 参考 锁紧系统直径

(1) Number of stages

(2) Application specific configuration with NCP - www.neugart.com

(3) The ratio-dependent values can be retrieved in Tec Data Finder - www.neugart.com

(4) More information on page 183

(5) Reference clamping system diameter

输出扭矩	Output torques			PLQE040	PLQE060	PLQE080	PLQE120	i ⁽¹⁾	p ⁽²⁾
周期性扭矩 ⁽³⁾⁽⁴⁾	Cyclic torque ⁽³⁾⁽⁴⁾	T _{2z}	Nm	11	28	85	115	3	1
				15	38	115	155	4	
				14	40	110	195	5	
				8,5	25	65	135	7	
				6	18	50	120	8	
				5	15	38	95	10	
				16,5	44	130	210	9	2
				20	44	120	260	12	
				18	44	110	230	15	
				20	44	120	260	16	
				20	44	120	260	20	
				18	40	110	230	25	
				20	44	120	260	32	3
				18	40	110	230	40	
				7,5	18	50	120	64	
				20	44	120	260	60	
				20	44	120	260	80	
				20	44	120	260	100	
				18	44	110	230	120	3
				20	44	120	260	160	
				18	40	110	230	200	
				20	44	120	260	256	
				18	40	110	230	320	
				7,5	18	50	120	512	
最大扭矩 ⁽³⁾⁽⁴⁾	Maximum torque ⁽³⁾⁽⁴⁾	T _{2max}	Nm	11	44	105	184	3	1
				24	60	140	245	4	
				22	64	175	310	5	
				13,5	40	104	215	7	
				9,5	28	80	192	8	
				8	24	60	152	10	
				16,5	70	205	335	9	2
				32	70	192	415	12	
				28	70	176	365	15	
				32	70	192	415	16	
				32	70	192	415	20	
				28	64	176	365	25	
				32	70	192	415	32	3
				28	64	176	365	40	
				12	28	80	192	64	
				32	70	192	415	60	
				32	70	192	415	80	
				32	70	192	415	100	
				28	70	176	365	120	3
				32	70	192	415	160	
				28	64	176	365	200	
				32	70	192	415	256	
				28	64	176	365	320	
				12	28	80	192	512	

PLQE

(1) 传动比 (i=n₁/n₂)
 (2) 减速机级数
 (3) 利用 NCP 针对应用进行专门设计 – www.neugart.com
 (4) 参考夹紧系统直径

(1) Ratios (i=n₁/n₂)
 (2) Number of stages
 (3) Application specific configuration with NCP – www.neugart.com
 (4) Based on reference clamping system diameter

PLQE

输出扭矩	Output torques			PLQE040	PLQE060	PLQE080	PLQE120	i ⁽¹⁾	p ⁽²⁾
连续扭矩 ⁽³⁾	Continuous torque ⁽³⁾	T _{2D}	Nm	3,5	22	37	97	3	1
				12,5	23	86	131	4	
				11,5	24	85	165	5	
				7	19,5	55	114	7	
				5	15	42	102	8	
				4	12,5	32	80	10	
				10,5	30	87	178	9	2
				14,5	32	102	220	12	
				15	35	93	195	15	
				17	35	102	220	16	
				17	37	102	220	20	
				15	34	93	195	25	
				17	37	102	220	32	3
				15	34	93	195	40	
				6	15	42	102	64	
				17	37	102	220	60	
				17	37	102	220	80	
				17	37	102	220	100	
				15	37	93	195	120	3
				17	37	102	220	160	
15	34	93	195	200					
17	37	102	220	256					
15	34	93	195	320					
6	15	42	102	512					

输入转速	Input speeds			PLQE040	PLQE060	PLQE080	PLQE120	i ⁽¹⁾	p ⁽²⁾
连续输入转速 ⁽³⁾⁽⁴⁾	Continuous input speed ⁽³⁾⁽⁴⁾	n _{1D}	min ⁻¹	5000	4500	4000	2150	3	1
				5000	4500	3200	2300	4	
				5000	4500	3850	2500	5	
				5000	4500	4000	3500	7	
				5000	4500	4000	3500	8	
				5000	4500	4000	3500	10	
				5000	4500	4000	2650	9	2
				5000	4500	4000	2750	12	
				5000	4500	4000	3000	15	
				5000	4500	4000	2850	16	
				5000	4500	4000	3350	20	
				5000	4500	4000	3500	25	
				5000	4500	4000	3500	32	3
				5000	4500	4000	3500	40	
				5000	4500	4000	3500	64	
				5000	4500	4000	3500	60	
				5000	4500	4000	3500	80	
				5000	4500	4000	3500	100	
				5000	4500	4000	3500	120	3
				5000	4500	4000	3500	160	
5000	4500	4000	3500	200					
5000	4500	4000	3500	256					
5000	4500	4000	3500	320					
5000	4500	4000	3500	512					
最高机械输入转速 ⁽³⁾	Max. mechanical input speed ⁽³⁾	n _{1max}	min ⁻¹	18000	13000	7000	6500		

(1) 传动比 (i=n₁/n₂)

(2) 减速级数

(3) 利用 NCP 针对应用进行专门设计 – www.neugart.com

(4) 参考夹紧系统直径

(1) Ratios (i=n₁/n₂)

(2) Number of stages

(3) Application specific configuration with NCP – www.neugart.com

(4) Based on reference clamping system diameter

输出扭矩	Output torques			PLQE040	PLQE060	PLQE080	PLQE120	i ⁽¹⁾	p ⁽²⁾
急停扭矩 ⁽³⁾⁽⁴⁾	Emergency stop torque ⁽³⁾⁽⁴⁾	T _{2Stop}	Nm	22	60	150	375	3	1
				30	80	200	500	4	
				36	80	220	500	5	
				26	80	178	340	7	
				27	80	190	380	8	
				27	75	200	480	10	
				33	88	260	500	9	2
				40	88	240	520	12	
				36	88	220	500	15	
				40	88	240	520	16	
				40	88	240	520	20	
				36	80	220	500	25	
				40	88	240	520	32	3
				36	80	220	500	40	
				27	80	190	380	64	
				40	88	220	520	60	
				40	88	240	520	80	
				40	88	240	520	100	
				36	88	220	500	120	
				40	88	240	520	160	
				36	80	220	500	200	
40	88	240	520	256					
36	80	220	500	320					
27	80	190	380	512					

PLQE

(1) 传动比 (i=n₁/n₂)
 (2) 减速机级数
 (3) 允许 1000 次
 (4) 参考夹紧系统直径

(1) Ratios (i=n₁/n₂)
 (2) Number of stages
 (3) Permitted 1000 times
 (4) Based on reference clamping system diameter

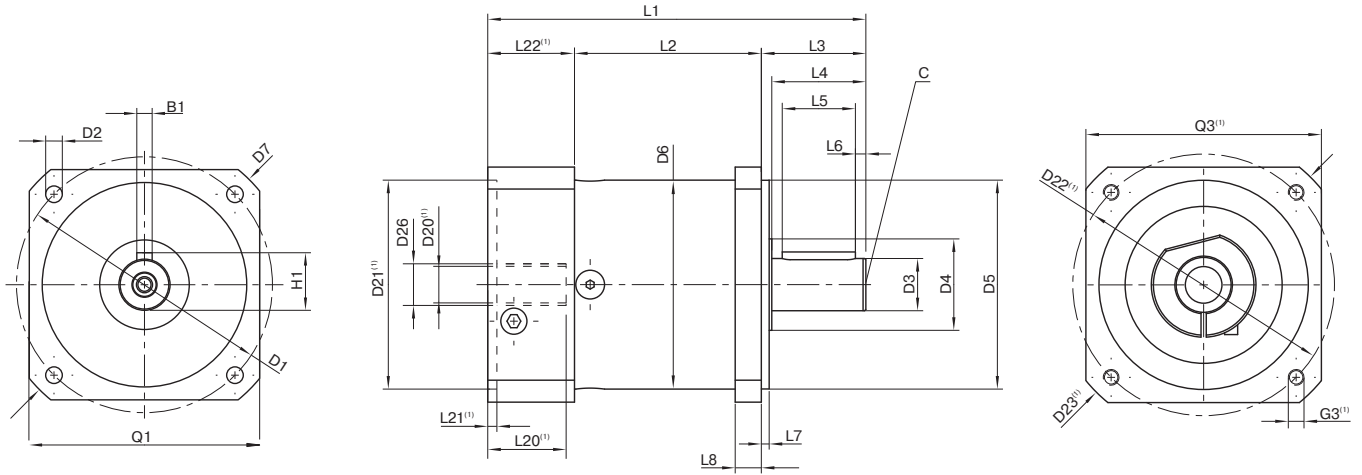

图示为带平键的 PLQE080 / 1 级 / 附带平键的输出轴 / 19 mm 锁紧系统 / 适配电机法兰 - 单一法兰 / B5 电机法兰类型
 Drawing corresponds to a PLQE080 / 1-stage / output shaft with feather key / 19 mm clamping system / motor adaptation - one part / B5 flange type motor

⁽¹⁾ 具体尺寸视电机/减速机法兰而定。可以在 www.neugart.com 下 Tec Data Finder。中针对每个电机适配电机特有的输入法兰几何尺寸。
⁽¹⁾ The dimensions vary with the motor/gearbox flange. The input flange dimensions can be retrieved for each specific motor in Tec Data Finder at www.neugart.com

几何尺寸 ⁽²⁾	Geometry ⁽²⁾			PLQE040	PLQE060	PLQE080	PLQE120	p ⁽³⁾	Code
输出端安装孔节圆直径	Pitch circle diameter output	D1		50	75	100	130		
输出端安装孔直径	Mounting bore output	D2	4x	3,4	5,5	6,5	8,5		
输出轴直径	Shaft diameter output	D3	h7	13	16	20	25		
输出轴轴肩直径	Shaft collar output	D4		17	20	35	35		
输出端定位凸台直径	Centering diameter output	D5	h7	35	60	80	110		
箱体直径	Housing diameter	D6		40	60	80	115		
输出法兰对角线尺寸	Diagonal dimension output	D7		57	92	116	145		
输出端法兰外方	Flange cross section output	Q1	■	42	70	90	115		
最小总长	Min. total length	L1		90	111	145	201,5	1	
				103	123,5	162,5	229,5	2	
				115,5	136	180	257	3	
箱体长度	Housing length	L2		35,5	55	71	99	1	
				48,5	67,5	89	127	2	
				61	80,5	106,5	154,5	3	
输出轴轴长	Shaft length output	L3		26	32	40	55		
输出端定位凸台深度	Centering depth output	L7		5,5	3	3	4		
输出端法兰厚度	Flange thickness output	L8		7	10	10	15		
电机轴直径 j6/k6	Motor shaft diameter j6/k6	D20		更多信息见第 191/192 页 More information on page 191/192					
输入端锁紧系统直径	Clamping system diameter input	D26		更多信息见第 28 页 More information on page 28					
带平键的输出轴 (DIN 6885-1)	Output shaft with feather key (DIN 6885-1)			A 5x5x14	A 5x5x20	A 6x6x28	A 8x7x40		A
平键宽度 (DIN 6885-1)	Feather key width (DIN 6885-1)	B1		5	5	6	8		
含平键在内的轴高 (DIN 6885-1)	Shaft height including feather key (DIN 6885-1)	H1		15	18	22,5	28		
到轴肩的距离	Shaft length from shoulder	L4		18	28	36	50		
平键长度	Feather key length	L5		14	20	28	40		
到轴端的距离	Distance from shaft end	L6		2	4	4	5		
中心孔 (DIN 332, DR 形)	Center hole (DIN 332, type DR)	C		M4x10	M5x12,5	M6x16	M10x22		
光滑输出轴	Smooth output shaft								B
到轴肩的距离	Shaft length from shoulder	L4		18	28	36	50		

⁽²⁾ 所有的尺寸单位为mm
⁽³⁾ 减速机级数

⁽²⁾ Dimensions in mm
⁽³⁾ Number of stages

